

## 6.3 Measurement of ferroresonance oscillations

Measurements of electrical signals can be taken within an installation containing inductive voltage transformers to determine whether ferroresonance oscillations could occur in the event of switching operations. If ferroresonance oscillations occur it can be investigated if and how quickly they subside. The important question is whether or not the occurring oscillations will lead to harmful currents in the primary winding of the voltage transformer.

For a basic analysis – as for verification of theoretical models – more detailed measurements are performed with simultaneous recording of primary and secondary voltages and the current through the primary winding of the voltage transformer. The results can then be compared with the theoretically determined wave forms. The effectiveness of damping devices can be investigated by measuring the current through the device.

Since the excitation of a ferroresonance oscillation is strongly dependent on the switching phase angle within a power frequency period, several switching trials should be performed in every investigated configuration.

As leaking currents at insulating surfaces in HV installations may significantly attenuate or even impede ferroresonance oscillations, the weather condition during experimental investigations in AIS should be taken into account.

Switching transients always produce strong electromagnetic interference. The used measuring system must therefore be designed with a high degree of immunity against electromagnetic transients. The special literature on rules of electromagnetic compatibility measurement practice may be consulted [61], Chapter 7.

### 6.3.1 Single-phase ferroresonance

The most sensitive measuring signal for detecting ferroresonance is the current through the primary winding of the voltage transformer, which will always provide clear indications of any existing ferroresonance oscillations (see Figure 6.2). In order to measure this current, which in normal operation amounts to a few mA, a current transformer or current probe is introduced at the ground connection of the high voltage winding X. In this case the current transformer must be able to transfer the subharmonic frequencies (3<sup>rd</sup> and 5<sup>th</sup> order). As an alternative to the current transformer the HV winding ground terminal can be opened and a resistive shunt of typically 10  $\Omega$  can be introduced (see Figure 6.3).

In the case of ferroresonance, the peak values of the current in the primary windings will be between 20 mA and a few 100 mA. Only in extreme cases will they be in the order of 1 A.

Note: The ground connection of the primary winding must never be opened during operation, since high voltage will otherwise arise at the terminal. As well for this reason, the resistor must be designed for the maximum possible current through the primary winding. An overvoltage protection element between the ground and the ground-side clamp of the primary winding is recommended as a safety measure.

Figure 6.2 and Figure 6.3 shows the measuring connections on a voltage transformer's terminal box.

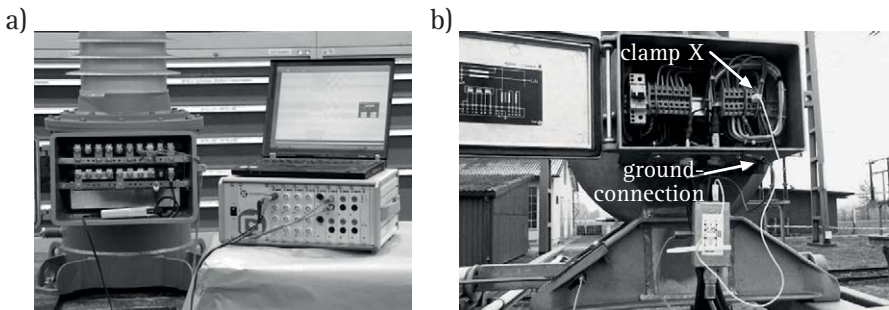

Figure 6.2 Example of the connection of a measuring resistor for capturing the current signal through the voltage transformer's primary winding at clamp X (see connection diagram in Figure 6.3) –

- a) current measurement with current clamp,
- b) current measurement with shunt resistor

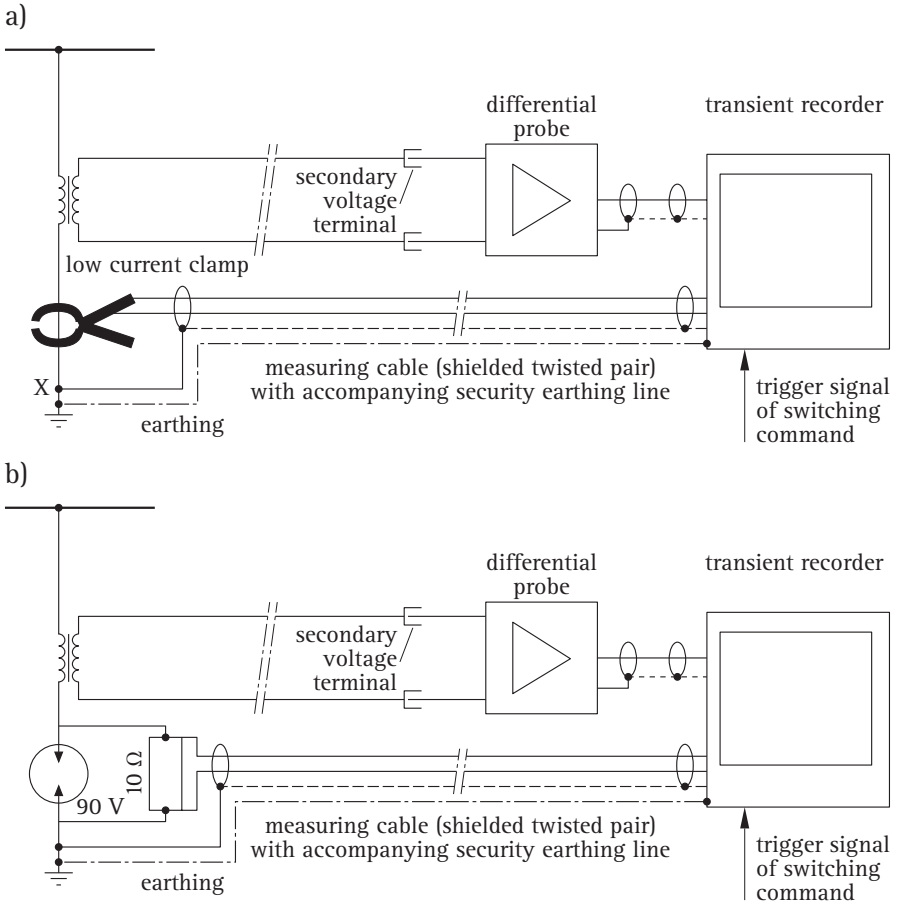
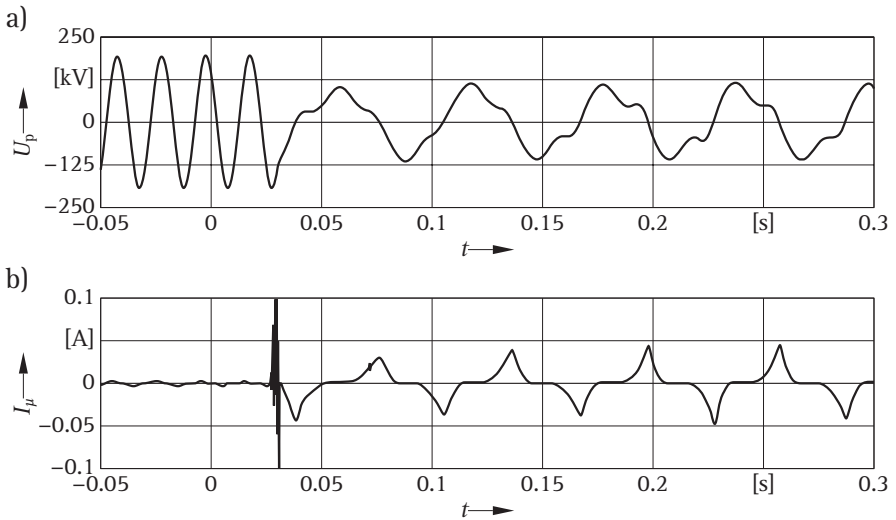

Figure 6.3 Current measurement through voltage transformer's primary winding and the voltage at the secondary winding –

- a) current measurement with current clamp,
- b) current measurement with shunt



**Figure 6.4** Measurement of a single-phase ferroresonance oscillation: Example of a measured stationary single-phase ferroresonance oscillation of  $16\frac{2}{3}$  Hz in a 220 kV AIS switching bay (compare circuit Chapter 3, Figure 3.4); upper trace: primary voltage, measured on the secondary winding; lower track: current through the voltage transformer's primary winding; the oscillogram shows a very low current through the primary winding (a few mA) before the switching operation; the first two current peaks reach 150 mA, after a short transient phase a continuous oscillation establishes with peak currents of 40-mA-current-peaks due to core saturation occur every third halve period; measurements by FKH, substation Mettlen/Switzerland

The degree of saturation can be seen from the narrow and high peak currents (Figure 6.4, lower oscillogram trace). Normally voltage signals at the secondary windings will also show oscillations (Figure 6.4, upper oscillogram trace); however if only voltages are measured, it is usually not possible to clearly distinguish between oscillations without core saturation and such with core saturation (ferroresonance) and whether dangerously high currents in the primary winding occur.

### 6.3.2 Three-phase ferroresonance

For test measurements of three-phase ferroresonance oscillations, a measurement is recommended at all three phases (Figure 6.5). As in the case of single-phase ferroresonance, the current in the primary winding should be registered. Saturation is directly evident from the current peaks caused by the core saturation. The voltage across the open delta connection should also be measured.

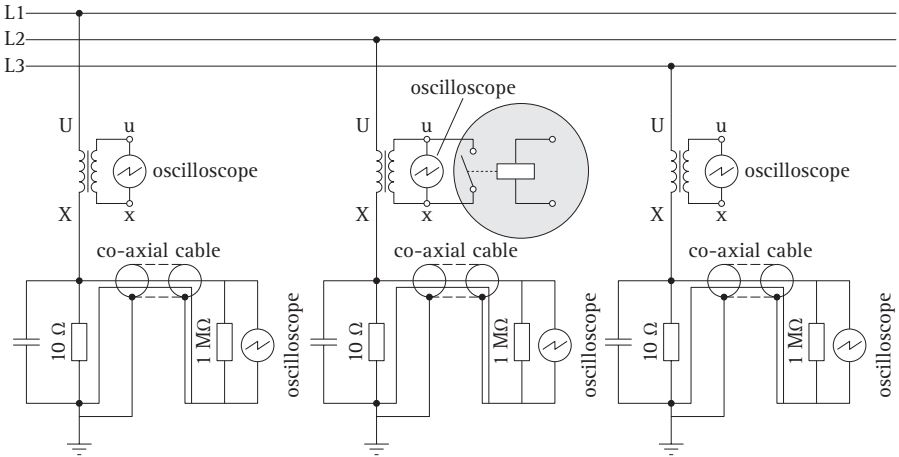

Figure 6.5 Measurement of three-phase ferroresonance oscillations with an oscilloscope; excitation of the oscillations on account of a secondary short circuit of a voltage transformer (dashed circle)

To determine whether a circuit configuration is critical to three-phase ferroresonance, the excitation by briefly (approximately 200 ms) short-circuiting the secondary winding of a voltage transformer can be regarded as the worst-case excitation condition and is often applied in practical tests [62]. With this method, the ferroresonance behavior can be tested protecting the feeding transformer from repeated switching transients on the primary voltage side.

An oscillogram sample of a three-phase ferroresonance oscillation is recorded in Figure 6.6. A MV bay with voltage transformers was switched to the feeding transformer. The asymmetric voltage distribution at the first moment led to an excitation of three-phase ferroresonance.

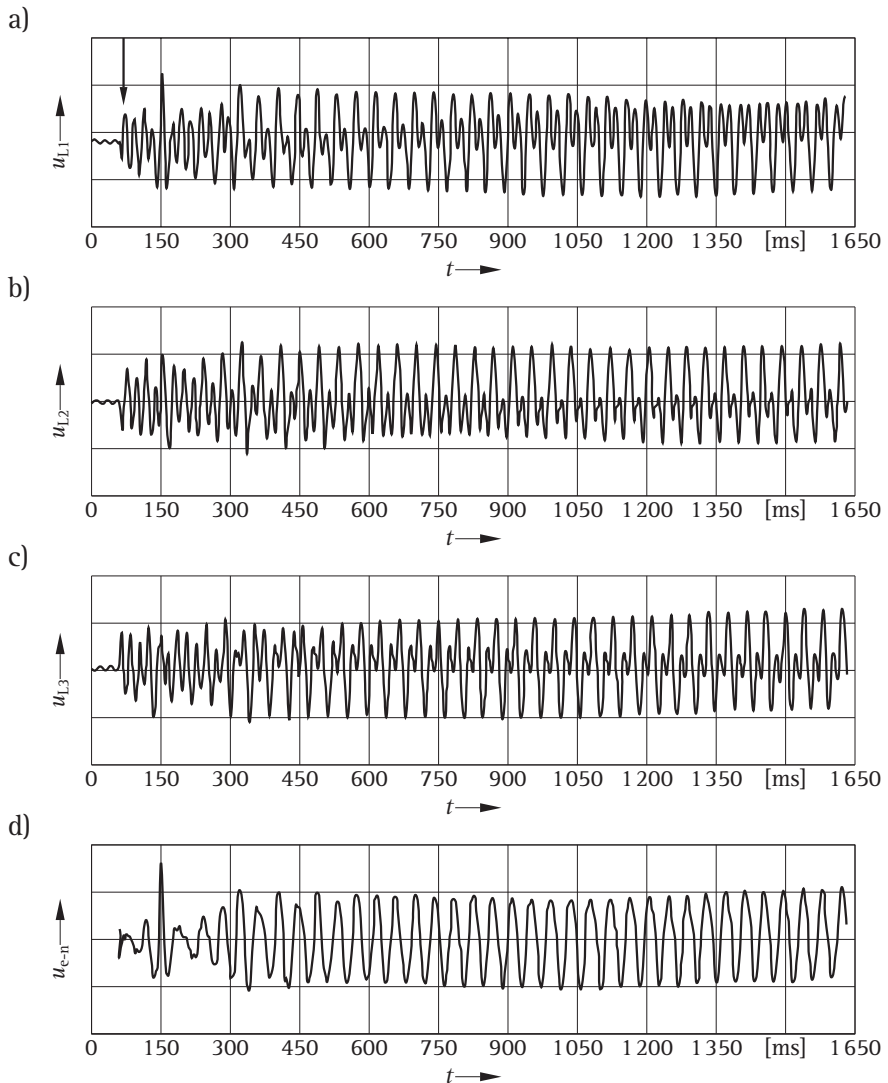

Figure 6.6 Fault recorder display of a three-phase ferroresonance oscillation; the voltage traces of the three phases L1 to L3 are displayed along with the voltage trace of the neutral e-n; the ferroresonance oscillation frequency deviates slightly from the second subharmonic 25 Hz (at power frequency 50 Hz); therefore the peak values of the ferroresonance voltage are drifting slowly from phase to phase

# 7 Prevention and measures against ferroresonance oscillations

## 7.1 Overview of measures to avoid ferroresonance oscillations

The Chapter deals in particular with prevention, by appropriate design of the substation and its components and with avoiding of ferroresonance oscillations during operation. In addition, measures for terminating active ferroresonance oscillations are discussed.

Figure 7.1 shows flow diagrams for the analyzing a high voltage switchgear in respect to the prevention of ferroresonance oscillations [52, 63].

The beginning of this process in the diagram is an assessment of weak points concerning the risk of single-phase or three-phase ferroresonance. To start with, it is important to distinguish between the procedure with an existing substation (left branch of the main flow diagram in the middle) and with a new substation (right branch).

In the following sections the measures stated below are discussed:

### Measures of design

- Optimized design of substations
  - reducing grading and coupling capacitances ( $C_g$ ,  $C_C$ ),
  - increasing the ground capacitance ( $C_e$ ),
  - use of the specified burden of the VT on secondary winding,
  - linearization of the magnetization characteristic of the voltage transformer by means of an air gap in the iron core;
- controlled switching operations,
- additional damping device on the secondary side of the VT.
- In the case of three-phase ferroresonance configurations: insertion of a damping voltage transformer on the lower voltage side neutral point of the main power transformer (see Chapter 4.4.4).

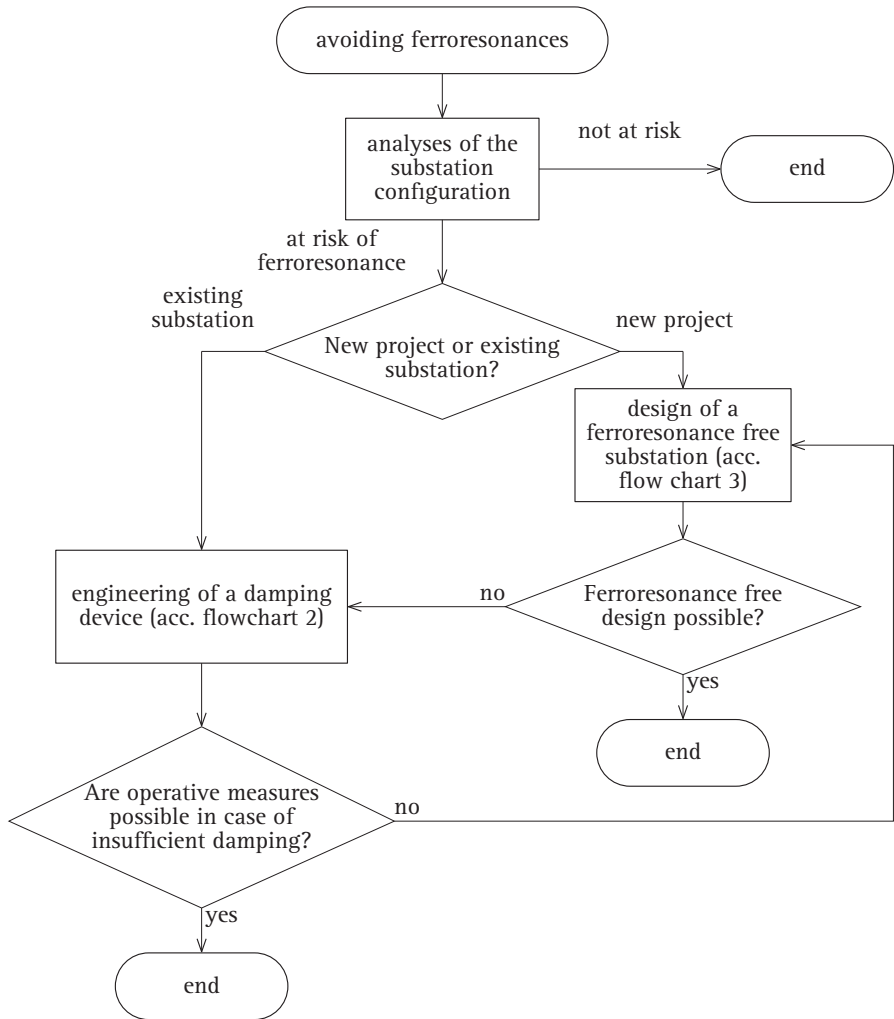

Figure 7.1 Flow diagrams for the analysis of ferroresonance oscillations – part 1



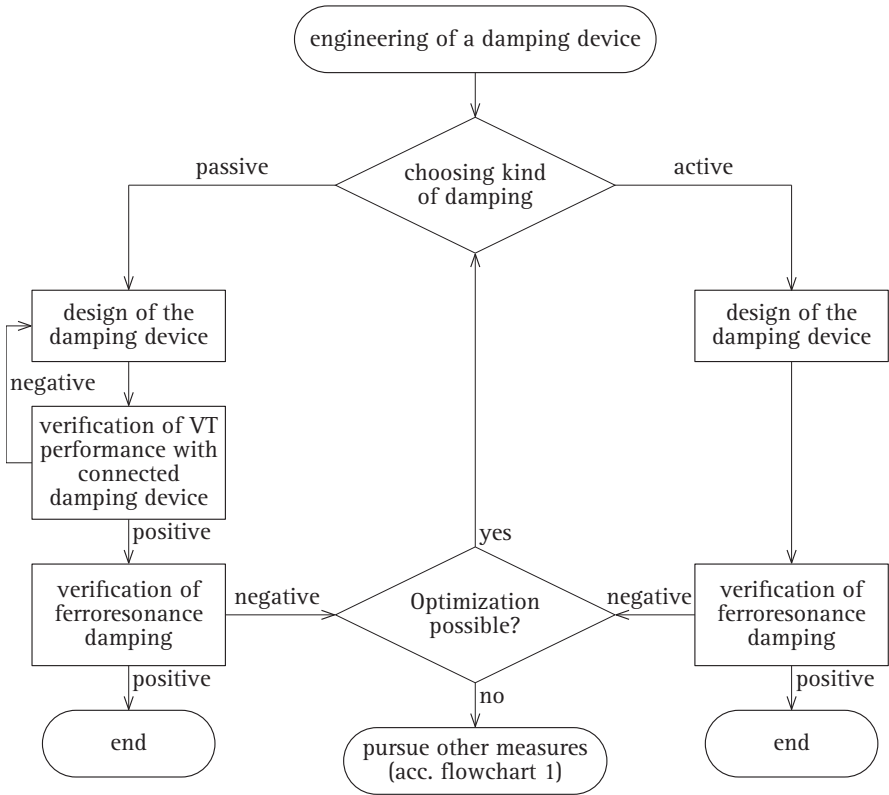

Figure 7.1 (continued) Flow diagrams for the analysis of ferroresonance oscillations – part 2

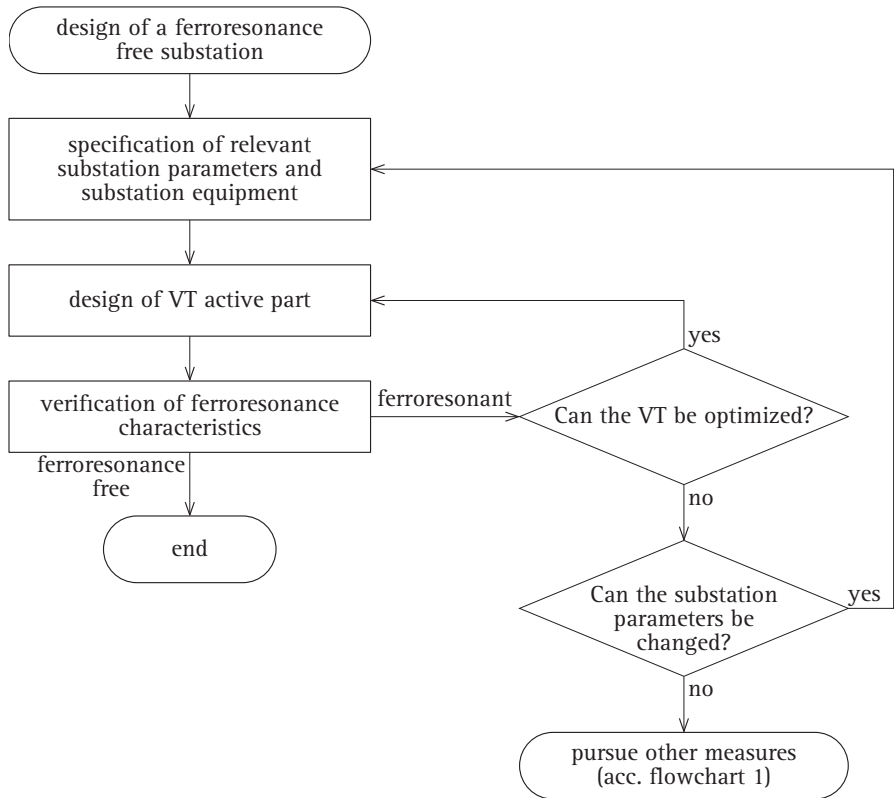

Figure 7.1 (continued) Flow diagrams for the analysis of ferroresonance oscillations – part 3

## 7.2 Definition of switching procedures to avoid ferroresonance oscillations

In general, ferroresonance oscillations can only be stimulated if portions of the network are disconnected and not grounded. Due to this fact it is especially important to pay attention to switching operations for testing purpose out of normal operation situations.

In the case of a single-phase steady-state ferroresonance oscillation in a configuration like that of Figure 7.2, there are three possibilities for eliminating the oscillations.

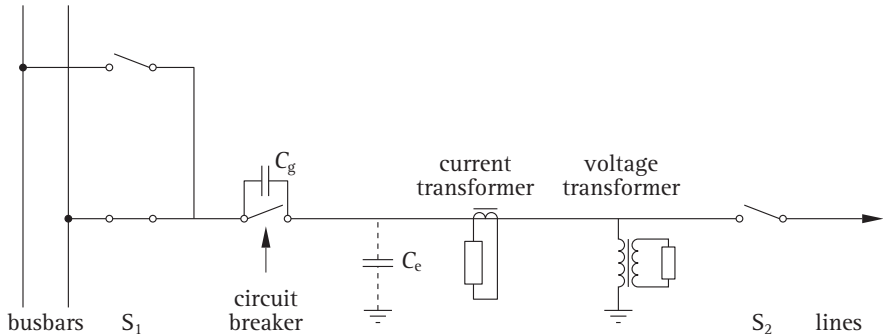

Figure 7.2 Single-line diagram for single-phase ferroresonance – opening of a circuit breaker with grading capacitors, with line disconnector open and busbar disconnector closed

First of all, the circuit breaker can be switched on again, in order to connect the voltage transformer to the network. Of course, this does not guarantee that there will be no ferroresonance oscillations the next time it is disconnected.

Secondly, the busbar disconnector can be shut off, as long as the interlocking system permits this operation. This is possible since only a small current is flowing. Thirdly, it is also possible to close the line disconnector, as long as the interlocking system permits.

Similar excitation conditions also apply for disconnecting an isolated busbar with inductive busbar voltage transformers (Figure 7.3).

The operation of the busbar coupling with closed disconnectors and open circuit breaker is to be avoided if the circuit breaker is equipped with grading capacitors. This configuration can lead to ferroresonance of the busbar voltage transformer with the capacitance of the grading capacitor of the coupling breaker. For this reason, the disconnector must be opened immediately after opening the coupling breaker. This also applies when disconnecting coupled busbars (voltage transformer in coupling bay Figure 7.4).

A further situation that may lead to the occurrence of single-phase ferroresonance oscillations is created when a disconnected section of power line is influenced by other circuits of a higher voltage level by stray capacitive coupling as shown in Figure 7.5 (see also Figure 3.6 in Chapter 3).

In the case of lines that are disconnected via the circuit breaker, the voltage transformer should therefore be disconnected from the interfering voltage by opening the line disconnector or by grounding the lines.

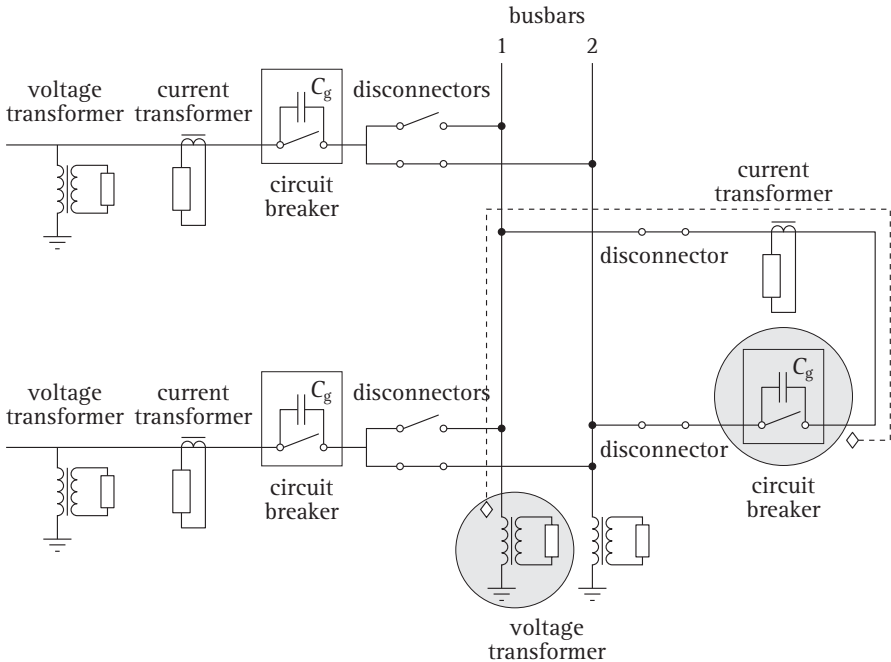

Figure 7.3 Single-line diagram for single-phase ferroresonance; disconnection of a busbar with inductive voltage transformers using a circuit breaker with grading capacitors, and with busbar disconnector closed

The probability of single-phase ferroresonance oscillation depends on the phase angle of the switching moment, i.e. the instant of the opening of the circuit breaker. In this case the probability of ferroresonance oscillation is reduced if the contact opening occurs at voltage zero crossing in each phase. If controlled switching is available ferroresonance oscillations may be avoided (see Chapter 2, Figure 2.9 and Chapter 5, Figure 5.15 and Figure 5.16).

For three-phase ferroresonance oscillation the excitation process is dependent on the voltage. For this reason the power transformer should be connected on the primary voltage side with the lowest secondary voltage given by the tap changer. If a three-phase ferroresonance should nevertheless occur, the low voltage side network must be connected as quickly as possible after the necessary voltage adjustment.

Should the ferroresonance oscillation nevertheless continue, or should an immediate connection not be possible on the low voltage side, then the primary voltage side circuit breaker of the transformer must be disconnected again.

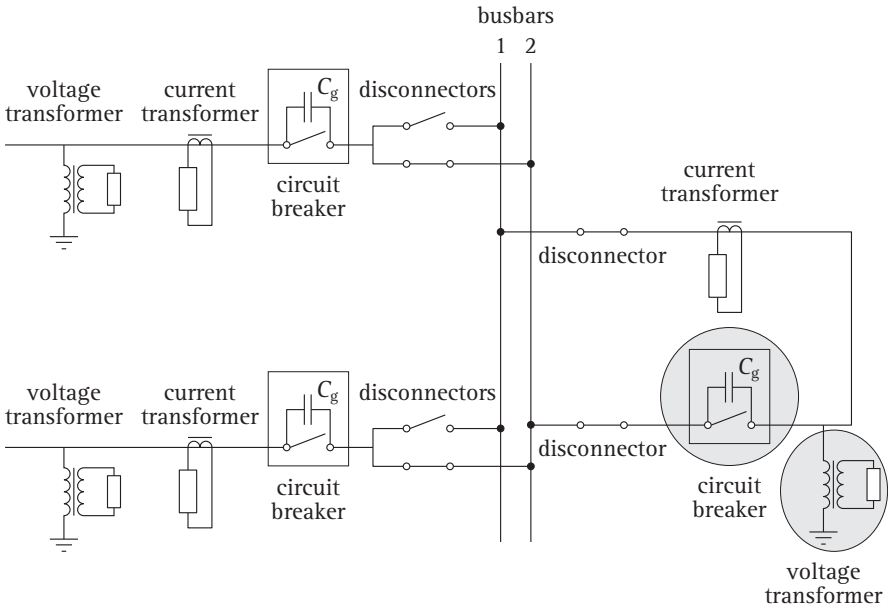

Figure 7.4 Single-line diagram for single-phase ferroresonance; disconnection of a coupling bay with inductive voltage transformers using a circuit breaker with grading capacitors and with busbar disconnector closed

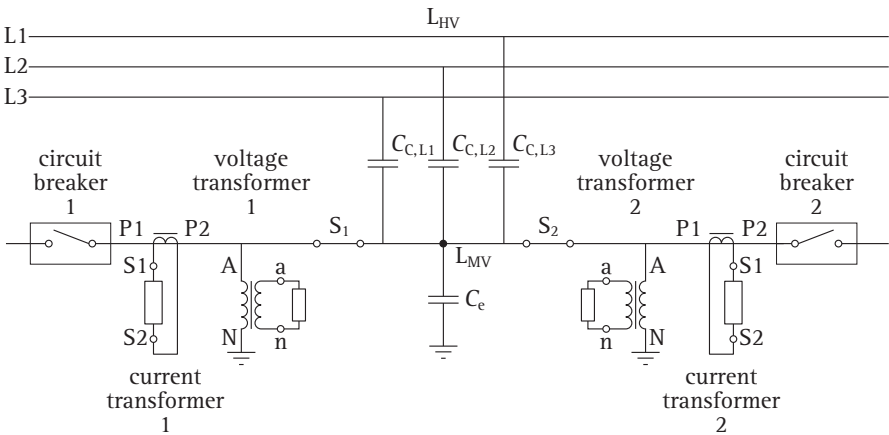

Figure 7.5 Example of a single-line diagram for single-phase ferroresonance; line to line interference by a parallel circuit of a higher voltage level